

ZARF50115-L-TV

滚针/推力圆柱滚子轴承

舍弗勒ID：
0016826440000

滚针/推力圆柱滚子轴承ZARF..-L，双向，
适合螺栓安装，长轴定位垫圈

技术信息

主要尺寸和性能数据

d	50 mm	Bore diameter
D	115 mm	Outside diameter
H	78 mm	Height
C_a	90,000 N	Basic dynamic load rating, axial
C_{0a}	300,000 N	Basic static load rating, axial
C_r	40,000 N	Basic dynamic load rating, radial
C_{0r}	82,000 N	Basic static load rating, radial
C_{ua}	28,000 N	Fatigue load limit, axial
C_{ur}	11,500 N	Fatigue load limit, radial
$n_{G\text{ Oil}}$	3,600 1/min	Limiting speed for oil lubrication
$n_{G\text{ Grease}}$	1,200 1/min	Limiting speed for grease lubrication
M_{RL}	2.2 Nm	Bearing friction torque
	2.022 kg	{重量}

安装尺寸

$D_{a\text{ max}}$	79 mm	Maximum diameter of housing shoulder
$d_{a\text{ min}}$	58 mm	Minimum diameter shaft shoulder
t_1	0.2 mm	Position bore in the housing

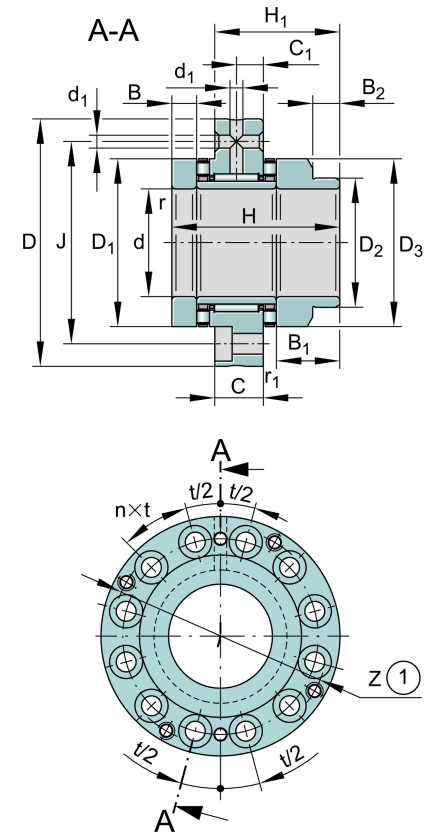

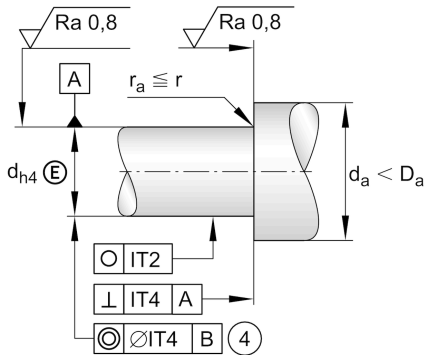
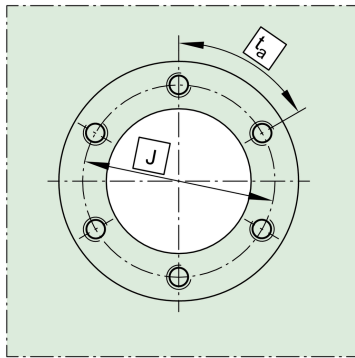
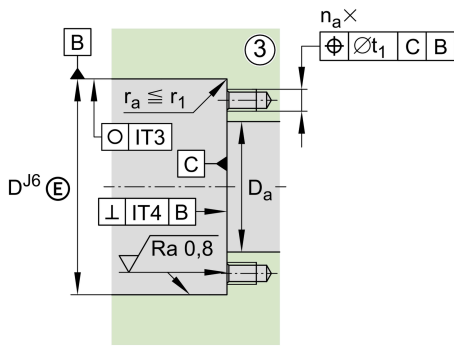

尺寸

H_1	58 mm	Height outer ring over wave washer
C	22.5 mm	Width, outer ring
C_1	12.5 mm	Distance to lubrication hole
D_1	78 mm	Rip diameter shaft washer
D_2	60 mm	Heeldiameter wave washer long
D_3	78 mm	Outside diameter wave washer long
B	11.5 mm	Width, wave washer
B_1	29.5 mm	Width wave washer long
B_2	14 mm	Width heel wave washer long
r_{min}	0.3 mm	Minimum chamfer dimension
r_{1min}	0.6 mm	Minimum chamfer dimension 1
d_1	6 mm	Diameter lubrication hole
J	94 mm	Pitch circle diameter (holes)
n	12	Number of screwing holes
$n \times t$	30 °	Split

温度范围

T_{min}	-30 °C	Operating temperature min.
T_{max}	120 °C	Operating temperature max.

附加信息

c_{aL}	4,800 N/μm	Rigidity axial
c_{kL}	2,470 Nm/mrad	Tilting stiffness
M_m	10.46 kg*cm ²	Mass moment of inertia
	1 μm	Axial runout
radial	ZMA50/75	Recommended INA precision locknut for radial locking (not included)
axial	AM50	Recommended INA precision locknut for axial locking (not included)
M_A	85 Nm	Tightening torque nut
	18,410 N	Required locknut force
	60X80X8	Rotary shaft seal to DIN 3760 (not included)
	M8	Size fixing screws DIN EN ISO 4762 10.9 (not included)
n_a	12	Number of screws
$na \times ta$	30 °	Division (screwing holes)