

KUVE35-B

球单轨引导系统

滑块 KWVE...-B, 标准滑块, 四列, 满装滚珠

技术信息

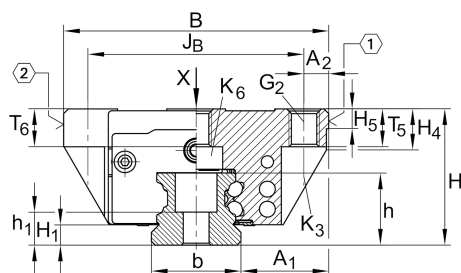

Main dimensions

l_{max}	[5,860] mm	Max length single piece guideway
H	[48] mm	height system
B	[100] mm	width carriage
L	[112] mm	overall length carriage

安装尺寸

C	[38,000] N	dynamic load rating
C_0	[72,000] N	static load rating
M_{0x}	[1,465] Nm	static moment rating about X axis
M_{0y}	[1,020] Nm	static moment rating about Y axis
M_{0z}	[1,020] Nm	static moment rating about Z axis

安装尺寸

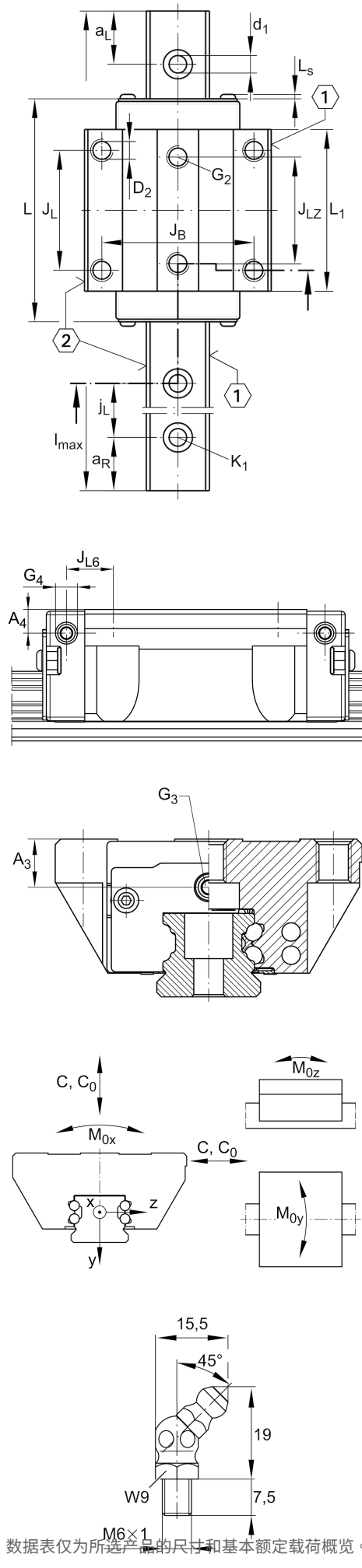

A_1	[33] mm	
J_B	[82] mm	
b	[34] mm	width rail
Tol_b	[-0.005] mm	Upper tolerance
Tol_b	[-0.03] mm	Lower tolerance
A_2	[9] mm	
L_1	[80] mm	
L_s	[1.65] mm	
J_L	[62] mm	
J_{LZ}	[52] mm	
j_L	[80] mm	
$a_{L\ min}$	[20] mm	
$a_{L\ max}$	[71] mm	
$a_{R\ min}$	[20] mm	
$a_{R\ max}$	[71] mm	
H_1	[6.7] mm	
H_4	[14.3] mm	
H_5	[6.75] mm	
T_5	[13] mm	
T_6	[12.3] mm	
h	[27] mm	
h_1	[14.5] mm	
G_2	[M10]	fixing screws
G_{2MA}	[41] Nm	maximum tightening torque
K_1	[M8]	fixing screws
K_{1MA}	[41] Nm	maximum tightening torque
K_3	[M8]	fixing screws
K_{3MA}	[41] Nm	maximum tightening torque
K_6	[M8]	fixing screws
K_{6MA}	[41] Nm	maximum tightening torque
d_1	[9] mm	
D_2	[8.6] mm	
A_3	[12.3] mm	
G_3	[M6] mm	
t_{G_3}	[7] mm	
A_4	[11] mm	
G_4	[M6]	
t_{G_4}	[7] mm	
J_{L6}	[16] mm	

数据表仅为所选产品的尺寸和基本额定载荷概览。请始终遵守本产品的所有更多信息和指南。您可以通过我们网站上的联系表了解更多信息。

Related products

[KWVE35-B]	Carriage
[TKVD35]	suitable Guide Rail