

ZARF35110-TV

滚针/推力圆柱滚子轴承

舍弗勒ID：
0016828300000

滚针/推力圆柱滚子轴承ZARF，双向，适合
螺栓安装

技术信息

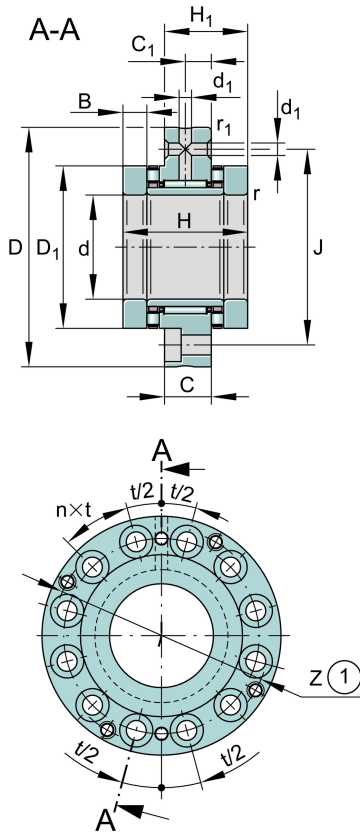

主要尺寸和性能数据

d	35 mm	Bore diameter
D	110 mm	外径
H	66 mm	Height
C_a	105,000 N	基本额定动载荷, 轴向
C_{0a}	265,000 N	基本额定静载荷, 轴向
C_r	27,500 N	基本额定动载荷, 径向
C_{0r}	53,000 N	基本额定静载荷, 径向
C_{ua}	22,900 N	疲劳极限载荷, 轴向
C_{ur}	7,600 N	疲劳极限载荷, 径向
$n_{G\text{Oil}}$	4,000 1/min	Limiting speed for oil lubrication
$n_{G\text{Grease}}$	1,250 1/min	Limiting speed for grease lubrication
M_{RL}	2.3 Nm	Bearing friction torque
	1.927 kg	{重量}

安装尺寸

$D_{a\text{max}}$	74 mm	Maximum diameter of housing shoulder
$d_{a\text{min}}$	60 mm	Minimum diameter shaft shoulder
t_1	0.2 mm	Position bore in the housing

尺寸

H_1	41 mm	Height outer ring over wave washer
C	18 mm	Width, outer ring
C_1	10 mm	Distance to lubrication hole
D_1	73 mm	Rip diameter shaft washer
B	14 mm	Width, inner ring
r_{min}	0.3 mm	最小倒角尺寸
$r_{1\text{min}}$	0.6 mm	Minimum chamfer dimension
d_1	3.2 mm	Diameter lubrication hole
J	88 mm	Pitch circle diameter (holes)
n	12	Number of screwing holes
$n \times t$	30 °	Split

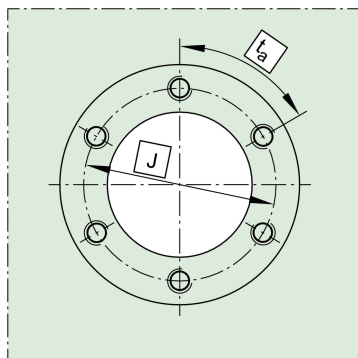

温度范围

T_{min}	-30 °C	最低工作温度
T_{max}	120 °C	最高工作温度

附加信息

c_{aL}	3,500 N/μm	Rigidity axial
c_{kL}	1,300 Nm/mrad	Tilting stiffness
M_m	8.47 kg*cm ²	Mass moment of inertia
	1 μm	Axial runout
radial	ZMA35/70	Recommended INA precision locknut for radial locking (not included)
axial	AM35	Recommended INA precision locknut for axial locking (not included)
M_A	100 Nm	Tightening torque nut
	27,480 N	Required locknut force
	M8	Screw size
n_a	12	Number of screws
$n_a \times t_a$	30 °	Division (screwing holes)

