

## KUVE45-B-ESC

球单轨引导系统

滑块 KWVE..-B-ESC, 窄短型滑块, 四列, 满装滚珠

### 技术信息

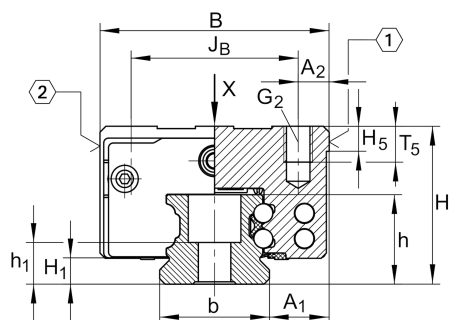

#### Main dimensions

$l_{max}$	[5,835] mm	Max length single piece guideway
H	[60] mm	height system
B	[86] mm	width carriage
L	[97.8] mm	overall length carriage

#### 安装尺寸

C	[46,500] N	dynamic load rating
$C_0$	[80,000] N	static load rating
$M_{0x}$	[2,060] Nm	static moment rating about X axis
$M_{0y}$	[883] Nm	static moment rating about Y axis
$M_{0z}$	[883] Nm	static moment rating about Z axis

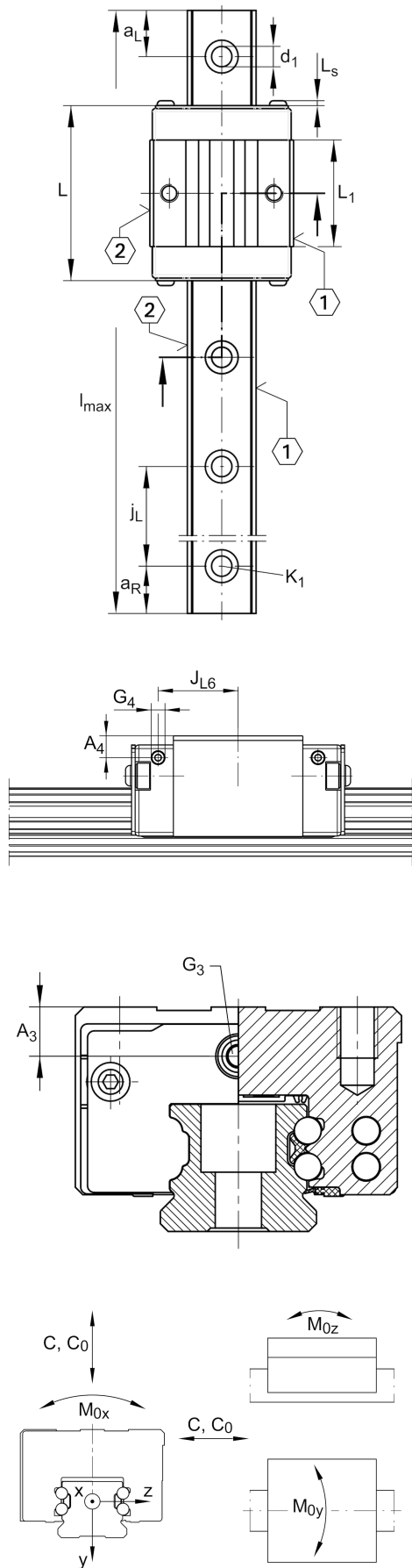

## 安装尺寸

$A_1$	[20.5] mm	
$J_B$	[60] mm	
$b$	[45] mm	width rail
$Tol_b$	[-0.005] mm	Upper tolerance
$Tol_b$	[-0.03] mm	Lower tolerance
$A_2$	[13] mm	
$L_1$	[59.7] mm	
$L_s$	[2.2] mm	
$j_L$	[105] mm	
$a_{L\ min}$	[20] mm	
$a_{L\ max}$	[94] mm	
$a_{R\ min}$	[20] mm	
$a_{R\ max}$	[94] mm	
$H_1$	[9.7] mm	
$H_5$	[9.25] mm	
$T_5$	[17] mm	
$h$	[34.2] mm	
$h_1$	[15.7] mm	
$G_2$	[M10]	fixing screws
$G_{2MA}$	[83] Nm	maximum tightening torque
$K_1$	[M12]	fixing screws
$K_{1MA}$	[140] Nm	maximum tightening torque
$d_1$	[13.4] mm	
$A_3$	[16.5] mm	
$G_3$	[M6] mm	
$t_{G_3}$	[7] mm	
$A_4$	[16.5] mm	
$G_4$	[M6]	
$t_{G_4}$	[7] mm	
$J_{L6}$	[37.9] mm	

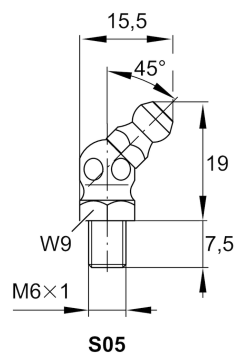

### Related products

[KWVE45-B-ESC]	Carriage
[TKVD45]	suitable Guide Rail